

Flow Measurement

SITRANS F US Clamp-on

Clamp-on ultrasonic flowmeters

Overview



SITRANS F US clamp-on ultrasonic flowmeters provide highly accurate measurement while minimizing installation time and maintenance expense.

Benefits

- Easy installation; no need to cut pipe or stop flow
- Minimal maintenance; external sensors do not require periodic cleaning
- No moving parts to foul or wear
- No pressure drop or energy loss
- Wide turn-down ratio
- Choice of single, dual or multiple channel versions and a variety of enclosures - to suit your operating conditions and requirements

Application

SITRANS F US clamp-on ultrasonic flowmeters have seven product families, each targeting specific applications:

FUS1010 and FUP1010 General purpose flowmeters are suitable for a wide variety of liquid applications, including the following:

- Water industry
 - Raw water
 - Potable water
 - Chemicals
- Wastewater industry
 - Raw sewage
 - Effluent
 - Sludges
 - Mixed liquor
 - Chemicals
- HVAC industry
 - Chillers
 - Condensers
 - Hot & cold water systems
- Power industry
 - Nuclear
 - Fossil
 - Hydroelectric
- Processing industry
 - Process control
 - Batching
 - Rate indication
 - Volumetric and mass measurement

FUE1010 Energy flowmeters are ideally suited to thermal energy/power industry applications, including:

- Chilled water sub-metering
- Hot water sub-metering
- Condenser water
- Glycol
- Thermal storage
- Lake source cooling

FUH1010 Oil flowmeters are ideal for applications carrying crude oil, refined petroleum or liquefied gas. There are three application areas: Interface detectors, volumetric flowmeters and mass or standard volume flowmeters

Interface detectors/density meters

- Precise identification of interfaces on multi-liquid pipelines
- Rapid and precise scraper "pig" indication
- Product identification
- Density indication

Viscosity compensated volumetric flowmeters

- Applications with multiple liquids having a wide viscosity range
- Automatic gross volume compensation due to viscosity changes

Standard volume (net) mass flowmeters

- Standard (net) volume flow measurement
- Suitable for use in leak detection systems
- Mass flow output measurement
- Interface detection
- Scraper ("pig") detection
- Chemical and petrochemical processing

FUG1010 Gas flowmeters are ideal for most natural and process gas industry applications, including:

- Checkmetering
- Allocation
- Flow survey verification
- Lost and unaccounted for (LAUF) analysis
- Production
- Storage

FST020 General purpose basic flowmeters are suitable for most clean liquid applications, including the following:

- Water & wastewater industry
 - Potable water
 - Wastewater, influent & effluent
 - Processed sewage, sludge
- Chemical feed industry
 - Sodium hypochlorite
 - Sodium hydroxide
- HVAC & power industries
 - Coolant flow
 - Fuel flow
- Process control
 - Chemicals
 - Pharmaceuticals

FUT1010 Flowmeters are suitable for liquid and gas applications, including the following:

- Liquid
 - Pipeline balancing
 - Terminal transmix metering
 - Refinery blending
 - Airport facility management
 - Petrochemical processing
 - Plant optimization
- Gas
 - Production wells
 - Underground storage
 - Transmission
 - Electric power generation
 - Gas processing plants

Function

Operating Principle

The SITRANS F US system is a transit-time ultrasonic meter that provides exceptional performance using a non-intrusive clamp-on approach. Ultrasonic sensors transmit and receive acoustic signals directly through the existing pipe wall, where the fluid refraction angle is governed by Snell's law of refraction.

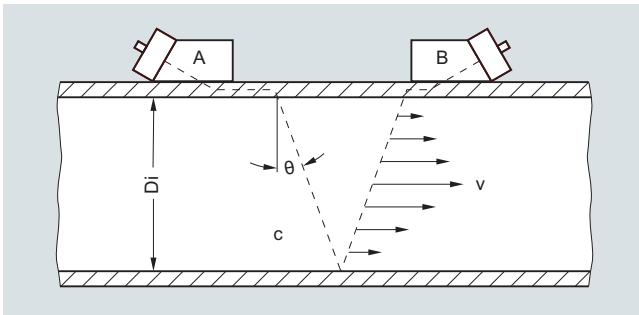

Clamp-on sensor mounted in a reflect configuration

The beam refraction angle is calculated as follows:

$$\sin\theta = c / V_{\phi}$$

c = Velocity of sound in fluid

V_{ϕ} = Phase velocity (a constant in the pipe wall)

The flowmeter automatically compensates for any change in fluid sound velocity (or beam angle) in response to variations in the average transit time between sensors A and B. By subtracting the computed fixed times (within the sensors and pipe wall) from the measured average transit time, the meter can then infer the required transit time in the fluid (T_{Fluid}).

The sound waves traveling in the same direction as flow ($T_{A,B}$) arrive earlier than sound waves traveling against the direction of flow ($T_{B,A}$). This time difference (Δt) is used to compute the line integrated flow velocity (v) as shown in the equation below:

$$v = V_{\phi} / 2 \cdot \Delta t / T_{\text{Fluid}}$$

Once the raw flow velocity is determined, the fluid Reynolds Number (Re) must be determined to properly correct for fully developed flow profile. This requires the entry of the fluid's kinematic viscosity (visc) as shown in the equations below, where Q represents the final flow profile compensated volumetric flow rate.

$$Re = Di \cdot v / \text{visc} \cdot Q = K(Re) \cdot (\pi / 4 \cdot Di^2) \cdot v$$

v = Flow velocity

$\text{visc} = \mu / \rho$ = (dynamic viscosity / density)

$K(Re)$ = Reynolds flow profile compensation

In wetted type ultrasonic flowmeters the meter constants are configured prior to leaving the factory. As this is not possible with clamp-on meters, the settings must be made by the customer at the time of installation. These settings include pipe diameter, wall thickness, liquid viscosity, etc.

SITRANS Clamp-On flowmeters that include temperature sensing can be configured to dynamically infer changes in fluid viscosity for the purpose of computing the most accurate flow profile compensation (K_{Re}).

Ultrasonic Sensor Types

Three basic types of Clamp-On sensors can be selected for use with the SITRANS F US flowmeter. The lower cost "universal" sensor is the most common type in the industry and is suitable for most single liquid applications where the sound velocity does not vary much. This sensor type can be used on any sonically conductive pipe material (including steel) making it well suited for portable survey applications. Universal sensors are selected

based on the pipe diameter range alone, so wall thickness is less important to the selection process.

The second sensor type is the patented WideBeam sensor (called high precision), which utilizes the pipe wall as a kind of waveguide to optimize the signal to noise ratio and provide a wider area of vibration. This makes this kind of sensor less sensitive to any change in the fluid medium.

The WideBeam sensor is designed for steel pipes, but can also be used with aluminum, titanium and plastic pipe. It is the preferred sensor for HPI and gas applications. Note that unlike the universal type, this sensor selection is dependent only on the pipe's wall thickness.

Automatic Zero Drift Correction (ZeroMatic Path™)

When WideBeam sensors are installed in the "Reflect" mode shown below, the acoustic signal travels in two different paths between sensors A and B. One path "ACB" travels through the pipe wall and fluid, while the other path "AB" never enters the fluid medium.

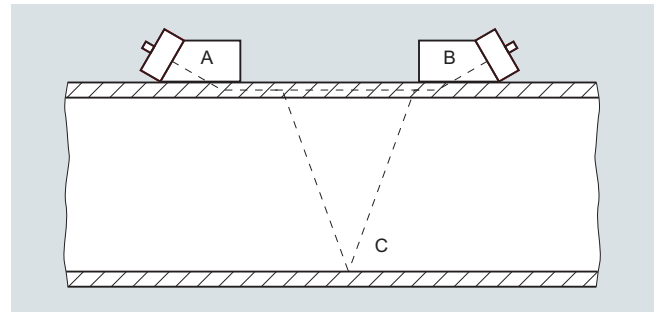

This later path provides the meter with a reference signal that is completely independent of flow rate and can therefore be used as a measure of sensor "mis-match". By continually analyzing this pipe wall signal the FUS1010 meter can dynamically correct for flow errors caused by zero drift.

Multi-Channel Flowmeters

For improved flow profile averaging, redundancy or better cost per measurement, Clamp-On meters can be supplied with 1 or 2 measurement channel, with 4 channel meters supplied as special order.

In the standard FUS, FUP, FUE systems, these channels can be installed on separate independent lines or in a multi-beam installation as shown below. This choice is made during meter setup, where either a multi-path (two paths on same pipe) or multi-channel installation can be selected.

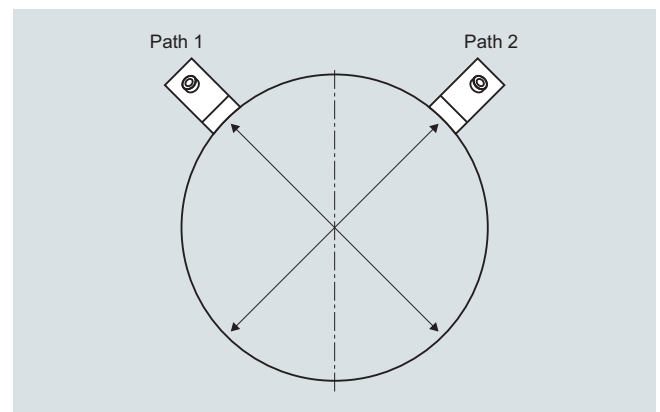

Dual path installation example

Flow Measurement

SITRANS F US Clamp-on

System information and selection guide

Doppler (Reflexor®) Operation

The Doppler measurement technique relies on the reflection of sound energy off tiny gas bubbles or suspended particles to create a doppler shift in the fixed frequency acoustic transmit signal, as shown below.

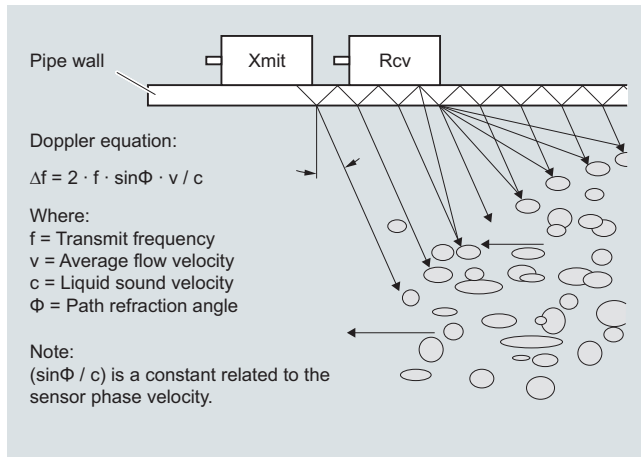

When de-demodulated using FFT signal processing, this doppler shifted frequency (Δf) can be used to measure the flow rate as described in the associated doppler equations below.

Although the standard transit time measurement system is very tolerant of high levels of liquid aeration and high solids content, there will be cases where insufficient signal will be available for operation with transit time mode. For these cases the FUS, FUP and FUE meters can be ordered with this optional doppler capability, which requires an additional doppler sensor.

SITRANS meter family description

SITRANS FUS1010 flowmeters

The FUS1010 system is a basic function permanent (or dedicated) clamp-on meter that is available with a full range of safety approvals, I/Os and enclosure types. This meter can be used in a wide range of applications but does not include the special functions found in the hydrocarbon FUH and energy FUE flowmeters.

The FUS1010 meter is typically programmed with a fixed viscosity and specific gravity entry, which can limit the mass flow and volumetric flow accuracy when highly variable (multi-product) liquid properties flow through the same pipeline.

If this meter is ordered with the Type 3 hardware and program configuration, it will have the ability to accommodate clamp-on RTDs, or an analog input from a temperature transmitter. With an active measurement of liquid temperature the meter can then be programmed to compensate for changes in liquid density and viscosity by mean of a "UniMass" table (for advanced users).

SITRANS FST020 flowmeters

The FST020 system has the same basic function of the FUS1010 system, but does not include the same I/O capability or safety approval rating of the FUS1010. This basic meter is intended for single liquid applications that do not require these additional features. Note that the FST020 is not available with hazardous area approvals.

SITRANS FUP1010 Portable flowmeters

The FUP1010 meter has all the capabilities of the FUS1010 meter, but in a battery powered portable configuration. This meter is ideal for general flow survey work where high accuracy is required. Note that the FUP meter is not available with hazardous areas approvals.

SITRANS FUE1010 Energy flowmeters

By combining clamp-on transit time flow measurement with accurate temperature differential measurement, the FUE1010 system provides a solution to thermal energy metering with no interruption of service. Energy measurement can be provided for water, ethylene glycol and brine solutions or steam condensate.

Absolute and differential temperature measurement is accomplished with the use of 2 matched 1 kΩ RTD elements installed on the supply and return side of the heating or cooling system. Efficiency calculation (kW/ton, EER or COP) is also available in systems with the optional analog input capability, which allow the meter to accept a power meter output.

The FUE1010 system is available in both dedicated (IP65 (NEMA 4X)) and portable configurations (IP40).

SITRANS FUG1010 Gas flowmeters

Be sure to contact a Siemens clamp-on specialist before placing a gas system order.

This unique Clamp-On gas meter uses the same WideBeam transit time operating principle described above. However, due to the very low density and sound velocity characteristics of gases, this meter requires a high gain signal amplifier and the installation of a pipe damping material.

The pipe damping material consists of an adhesive backed viscoelastic film that is designed to attenuate any stray acoustic transmit energy that may otherwise interfere with the transit time gas signal. Damping material installation requires a clean (grease free) pipe surface with well bonded paint.

The Clamp-On gas meter is capable of operation on most gases (natural gas, oxygen, nitrogen, carbon monoxide, etc) with a typical minimum operating pressure of 10 barg (145 psig). Low molecular weight gases such as helium or hydrogen can also be measured, but at a higher minimum pressure.

Standard volume computation: Can provide a standard volume or mass flow output for fixed gas compositions. All FUG1010 Gas meters include analog input capability that can be used for pressure and temperature compensation. With the installation of an AGA8 lookup table this meter can dynamically adjust the compressibility factor (Z_{act}) in response to changes in gas pressure and temperature, as indicate below:

$$\text{Std. Rate} = Q_{act} \cdot P_{act}/P_{base} \cdot T_{base}/T_{act} \cdot Z_{base}/Z_{act}$$

SITRANS FUH1010 Hydrocarbon flowmeters

There are three models of flowmeters included in the FUH1010 family, a viscosity compensated model, used for applications that will flow a wide range of viscosity, and a standard volume (Mass) model. Both models rely on a variable referred to as "liquident", which is used to infer the liquid's viscosity and optionally the liquid's density. This variable represents the measured liquid sonic velocity compensated by the operating temperature and pressure, so for a given liquid product the measured liquident output will remain constant over a wide range of pressure or temperature.

PV (Viscosity Compensation) Option:

This is the lower cost FUH meter option that uses the liquident variable to infer only the actual liquid viscosity. This meter does NOT provide the standard volume, mass flow, liquid identification or density output available in the DV meter option described below. The PV meter is suitable for any petroleum application where actual volume required as the input to an external RTU or flow transmitter.

System information and selection guide

DV (Standard Volume) Option:

This Liquident variable can also be used to identify the liquid's name (gasoline, fuel oil, crude oil, etc) as well as its physical properties (specify gravity, API, viscosity and compressibility) at base conditions. With this information the meter can be configured to output a temperature and pressure compensated (Standard) volume flow rate using the API 2540 and API MPMS chapter 11.2.1 methods as shown below.

Correction for Temperature:

Compute Thermal Expansion Coefficient (α_b):

$$\alpha_b = KO / \rho_b^2 + K1 / \rho_b$$

where: KO and K1 are constants dependent on type of liquid and ρ_b is the liquid density at base conditions

Compute temperature correction factor (K_T):

$$K_T = \rho_b * \text{EXP}(-\alpha_b \Delta T (1 + 0.8 \alpha_b \Delta T))$$

where: $\Delta T = (T - \text{base temperature})$

Correction for Pressure:

Compute Compressibility Factor (F):

$$F = \text{EXP}(A + B T + (C + D T) / \rho_b^2)$$

where: A, B, C and D are constants, and "T" is liquid temperature

Compute pressure correction factor (K_p):

$$K_p = 1 / (1 - F (P_{\text{act}} - P_{\text{base}}) * 10^{-4})$$

Final Volume Correction: $Q_{\text{std}} = Q_{\text{act}} * K_t * K_p$

Available outputs from this meter include: API, Density, Mass Flowrate, Standard Volume Flowrate and Liquid Identification.

B (Interface Detection) Option:

This meter option is designed to provide all the Non-Flow capabilities of a DV meter, making it an ideal non-intrusive alternative to a densitometer, interface detector or pig detector. Be aware that this meter does NOT measure flow rate.

SITRANS FUT1010

The FUT1010 is available in two different configurations; a version for liquid hydrocarbon applications and a version for precise gas measurement. Both versions are offered in pipe sizes ranging from 4 inch to 24 inch (DN100 to DN 600) with flange ratings of ANSI Class gas.

General Installation Guidelines for transit time Clamp-On Sensor

- Minimum measuring range: 0 to ± 0.3 m/s velocity (see meter accuracy graph below for more detail)
- Maximum measuring range: 0 to ± 12 m/s (± 30 m/s for high precision sensors). Final flow range determination requires application review

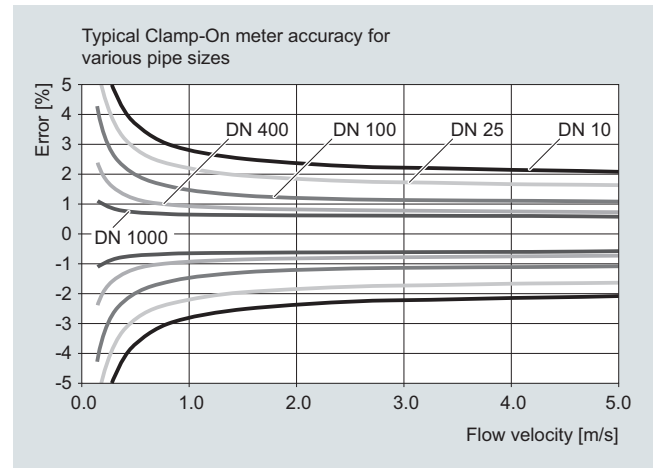

- Pipe must be completely full within the sensor installation volume for accurate flow measurement
- Typical MINIMUM straight pipe requirements are: 10 Diameters upstream / 5 Diameters downstream. Additional straight run is required for double out-of-plane elbows and partially open valves. A minimum of 20 upstream diameters is recommended for clamp-on gas systems
- Sensors should be installed at least 20° off vertical for horizontal pipes. This reduces the chance of beam interference from gas buildup at the top of the pipe
- Operation inside the Reynolds transition region, between $1000 < Re < 5000$ should be avoided for best accuracy
- Submersible and direct burial installations can be accommodated. Consult sales representative for details
- Ultrasonic coupling compound is provided with all sensor orders. Insure that a permanent coupling compound is used for long term installations
- Refer to the "Sensor type selection guide" to insure proper application of the equipment