



# ALL SS PRESSURE GAUGE CAPSULE



## SPECIAL FEATURES

- STAINLESS STEEL CASE & RING
- MOST SUITABLE FOR AIR & GASEOUS APPLICATION MEASUREMENT FROM 25 mBAR TO 600 mBar
- BOTTOM & BACK MOUNTING
- VACUUM & COMPOUND RANGES
- STANDARD FOLLOWED IN GENERAL EN 837-3 / IS 3624

## APPLICATIONS

FOOD & BEVERAGES, PHARMACEUTICAL, CONVENTIONAL & NUCLEAR POWER PLANTS, DRAFT MEASUREMENT

## SPECIFICATIONS

**STANDARD VERSION : 63mm , 100mm , 115mm, 150mm**

Accuracy	:	± 1.6% of F.S.
Ambient temperature	:	- 25°C to + 65°C
Process temperature	:	Max 100°C
Operating pressure	:	75 % of the Scale Value
Case	:	AISI 304 SS
Ring	:	AISI 304 SS, Bayonet Type
Socket	:	AISI 316L SS
Movement	:	Brass [ Chrome Plated ]
Joints	:	Tig Argon Arc Welding
Capsule	:	AISI 316 SS
Protection	:	IP 55
Dial	:	Aluminium, black graduation on white background
Pointer	:	Aluminium, black Coloured Micrometer Zero Adjustable (Fixed for NS 63 mm)
Window	:	Sheet Glass



# ALL SS PRESSURE GAUGE CAPSULE



**TYPE 2**

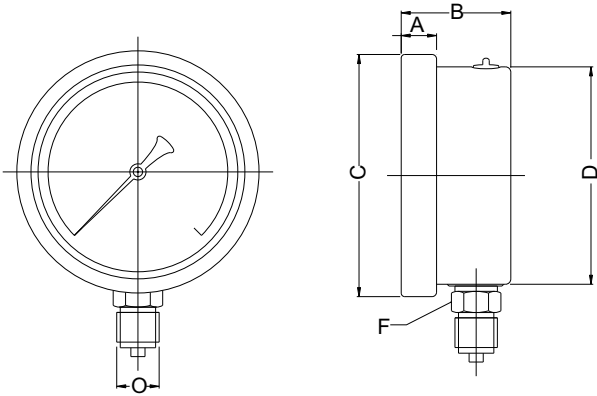

NS	A	D	F	H	I	L	U	Wt
63	10	43	10	68.5	61.5	53	14	0.13Kg

**TYPE 4**

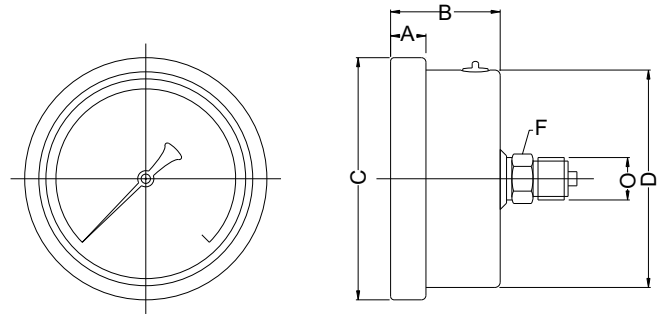

NS	A	D	H	I	N	U	Wt
63	10	43	68.5	61.5	54	14	0.13Kg

**TYPE 5**

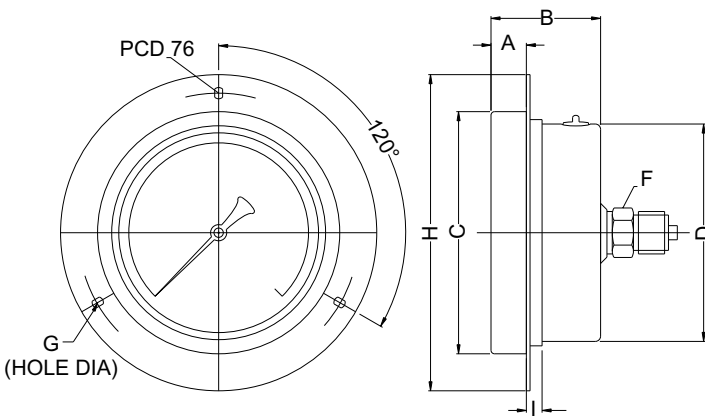

NS	D	H	I	K	N	O	P	U	Wt
63	43	68.5	61.5	4	54	86	76.5	14	0.15kg

**TYPE 9**

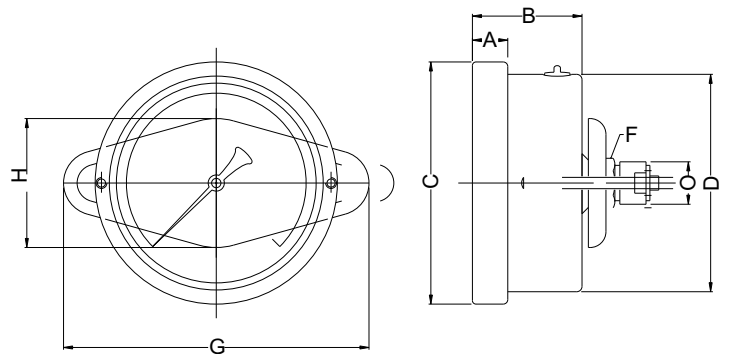

NS	B	D	H	I	N	Q	U	W	Wt
63	13	43	68.5	61.5	54	68.5	14	67	0.14kg

(\*WEIGHTS MENTIONED ARE FOR STANDARD VERSION.)  
Notes : • Drawings are not to scale. • All Dimensions are in mm. • NS = Nominal Size.



# ALL SS PRESSURE GAUGE CAPSULE



## DIMENSIONS - STANDARD VERSION TYPE - 1

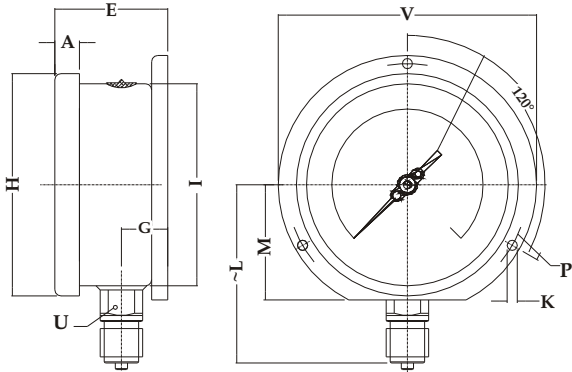

NS	A	E	G	H	I	K	~L	M	P	U	V	WT (kg)
100	12	55	20	110.5	100	6	100	56	120	22	128	0.70
115	11.5	55	23	131	118.5	5.6	95	67	137	22	160	0.78
150	16	54	23.5	164.5	149	7	115	82	174	22	191	1.15

## TYPE - 2

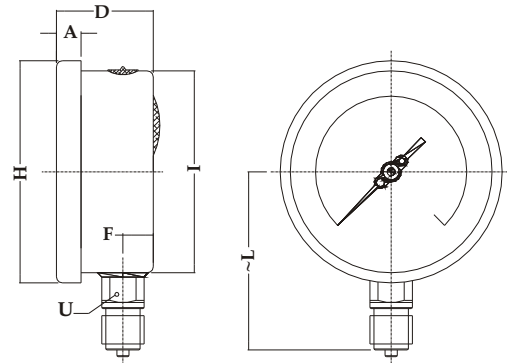

NS	A	D	F	H	I	~L	U	WT(kg)
100	12	47	16.5	110.5	100	90	22	0.64
115	11.5	49	16.5	131	118.5	95	22	0.70
150	16	49	16.5	164.5	149	108	22	1.05

## TYPE - 3

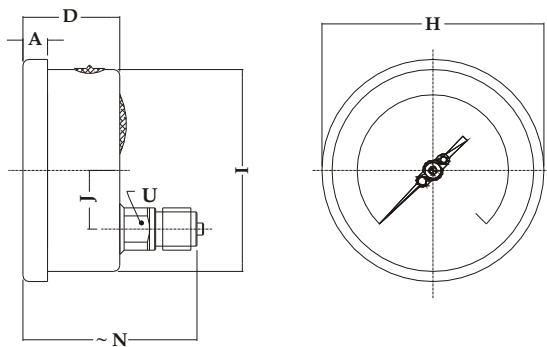

NS	A	D	H	I	J	N	U	WT.
100	12	47	110.5	100	21	87	22	0.66
115	11.5	47	131	118.5	30	87	22	0.72
150	16	49	164.5	149	46	92	22	1.02

## TYPE - 5

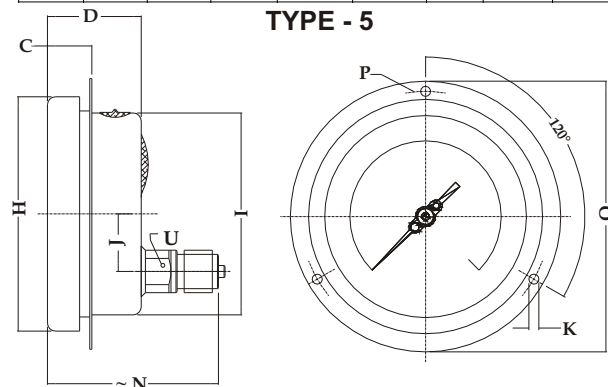

NS	C	D	H	I	J	K	~N	O	P	U	WT(kg)
100	12	47	110.5	100	30	6	87	125	115	22	0.72
115	20	49	131	118.5	30	5.6	87	160	137	22	0.80
150	16	49	164.5	149	46	6.5	91	188	174	22	0.7

## TYPE - 9

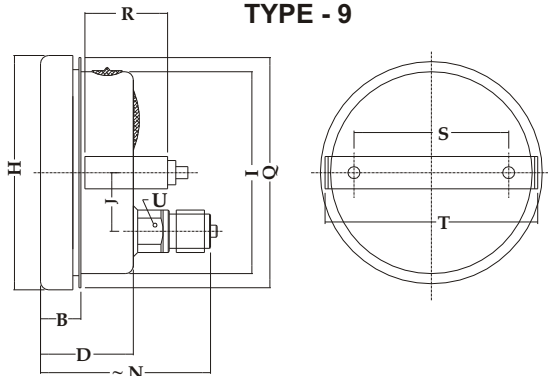

NS	B	D	H	I	J	N	Q	R	S	T	U	WT (kg)
100	21	47	110.5	100	30	87	115	40	70	105	22	0.71
115	20	49	131	118.5	30	87	132	43	80	130	22	0.78
150	16	49	164.5	149	48	92	165	43	105	158	22	1.12

(\*WEIGHTS MENTIONED ARE FOR STANDARD VERSION.)

Notes : • Drawings are not to scale. • All Dimensions are in mm. • NS = Nominal Size.



# ALL SS PRESSURE GAUGE

## CAPSULE

### RANGE TABLE

**Note :** Waaree offers National / International Scales like mbar, Pa, KPa, inWC, MWC, inHg, mmHg & Dual Scale or Equivalent scales as per the requirement can be provided on request. **Following are the example tables for mmWC scales**



### PRESSURE RANGE

SINGLE SCALE - mmWC				
RANGE	RANGE	RANGE	RANGE	RANGE
0/250	0/600	0/1600	0/2500	0/6000
0/400	0/1000	0/2000	0/4000	

### VACUUM & COMPOUND RANGE

SINGLE SCALE - mmWC				
RANGE	RANGE	RANGE	RANGE	RANGE
- 250/0	- 600/0	- 1600/0	- 2500/0	- 6000/0
- 400/0	- 1000/0	- 2000/0	- 4000/0	

SINGLE SCALE - mmWC				
RANGE	RANGE	RANGE	RANGE	RANGE
- 100/150	- 200/400	- 600/1000	- 1000/1500	- 2000/4000
- 150/250	- 400/600	- 800/1200	- 1500/2500	

## HOW TO ORDER

### BASIC MODEL

		<b>AF</b>																					
<b>NOMINAL SIZE</b>																							
D	63mm	G	115mm																				
F	100mm	H	150mm	<b>H</b>																			
<b>TYPE OF MOUNTING</b>																							
1 (A) WALL/ (B) SURFACE/ (C) PROJECTION MOUNTING WITH BOTTOM ENTRY ( NOT IN 63 mm SIZE)																							
2 DIRECT BOTTOM ENTRY																							
3 DIRECT LOWER BACK ENTRY																							
4 DIRECT CENTER BACK ENTRY ( ONLY IN 63 mm SIZE )																							
5 FLUSH PANEL BACK ENTRY WITH FRONT FLANGE																							
9 BACK ENTRY WITH MOUNTING BRACKET																							
<b>GAUGE CONNECTION</b>																							
2BM 1/4" BSP (M) STANDARD FOR NS 63 mm		3NM 3/8" NPT (M)																					
3BM 3/8" BSP (M) STANDARD		4NM 1/2" NPT (M)		<b>4BM</b>																			
4BM 1/2" BSP (M) STANDARD FOR NS 100,115 & 150 mm		2NF CARTRIDGE CONNECTION																					
ADAPTORS CAN BE PROVIDED FOR NON STD, FLARED & FEMALE CONNECTIONS																							
<b>RANGE</b>																							
REFER TABLES																							
<b>OPTIONS</b>																							
PS AISI 316 CASE & RING												RZ TOUGHENED GLASS											
PW FIVE POINT FACTORY CALIBRATION CERTIFICATE												SG OXYGEN SERVICE											
QB DAMPENING SCREW IN AISI 316 SS												SW DIAL TAG MARKING											
RH CUSTOM DESIGNED DIAL												SX SS TAG PLATE											
RW PLEXI GLASS												SC AISI 304 SS MOVEMENT											
RX SHATTERPROOF GLASS												<b>PW</b>											
<b>ELECTRIC CONTACTS (WITHOUT IP 55, NOT AVAILABLE IN NOMINAL SIZE D,G; ONLY ABOVE 400 mmWC)</b>																							
<b>INDUCTIVE TYPE (220 Vac, 4 A)</b>																							
YW Single NORMALLY OPEN																							
YV Single NORMALLY CLOSED																							
YX Double NORMALLY CLOSED + NORMALLY OPEN																							
YY Double NORMALLY OPEN																							
YZ Double NORMALLY CLOSED																							
ZA Double NORMALLY OPEN + NORMALLY CLOSED																							

ALSO AVAILABLE WITH 125 MM PHENOL CASE: PLEASE CONSULT THE FACTORY

Note: Due to continuous changes the specification may vary from time to time

334-02