

### Features

- for continuous level measurement of non-aggressive liquids (without hard dirtiness) in non-pressure reservoirs, drill holes, water wells, sumps, tanks and swimming-pools
- 2-wire connection with  $4 \div 20$  mA output
- 3-wire connection with  $0 \div 10$  V output
- optional arbitrance range up to 200 m (H<sub>2</sub>O)
- over voltages protection inside probe and at the beginning of cable
- carrying loop for easy fixation in a big depth



### Description

Hydrostatic level meters HLM-25 and HLM-16 are compact measuring devices containing silicon tenzometric sensor and evaluation electronics in stainless housing. From the probe housing coming out 2-wire cable with capillary (for comparing atmospheric pressure into probe).

Opposite end of the probe has stainless dismountable cover (to protect damage of membrane).

Hydrostatic level meters HLM are intended for continuous level measurement of non-aggressive liquids without hard dirtiness in non-pressure reservoirs, drill holes, water wells, sumps, tanks and swimming-pools. The principle of hydrostatic level measurement is the dependability of pressure on the height of the column of measured liquid.

For measuring it is possible to use a standard measuring ranges or directly define needed range. On the level meter are not any setting elements.

### Technical specification

Working areas (acc. to EN 60079-14) and performance

HLM-16N

non-explosive

HLM-25N

non-explosive

Type	HLM-16N	HLM-25N
Basic measuring ranges	10 ; 25 ; 40 ; 60 ; 100 m H <sub>2</sub> O	1 ; 1,6 ; 2,5 ; 4 ; 6 ; 10 ; 25 ; 40 ; 60 ; 100 m H <sub>2</sub> O
Permissible overcharge: - range 1 m H <sub>2</sub> O - further ranges	10 x range	40 x range 25 x range
Output	$4 \div 20$ mA	$4 \div 20$ mA or $0 \div 10$ V DC
Supply voltage for I / U output	$10 \div 30$ V DC / ---	$10 \div 30$ V DC / $15 \div 30$ V DC
Basic accuracy: - range 1 m H <sub>2</sub> O (of total range) - ranges until 4 m H <sub>2</sub> O (of total range) - other ranges over 4 m H <sub>2</sub> O (of total range)	0,5 %	0,6 % 0,3 % 0,2 %
Hysteresis, repeatability	0,05 %	
Long-term stability	0,1 % / year or 1 cm H <sub>2</sub> O / year	
Temperature error	max. 0,04 % / K	
Range of temperature compensation (standard)	0 to 25 °C	
Ambient temperature ranges (temperature of medium): - range until 20 m H <sub>2</sub> O - range over 20 m H <sub>2</sub> O	0 to +50 °C	-25 to +75 °C -25 to +50 °C
Protection degree	IP 68	
Cable isolation	Polyuretan	
Probe material	1.4404 (AISI 316L)	
Max. stress resistance (on U = 24 V)	$R_{max} = 675 \Omega$	
Weight of probe (without cable)	c. 0,4 kg	c. 0,6 kg

## Dimension drawing

### HLM-25N

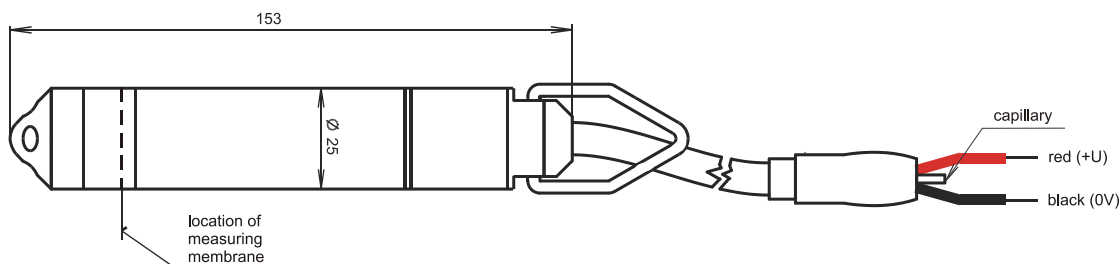

### HLM-16N

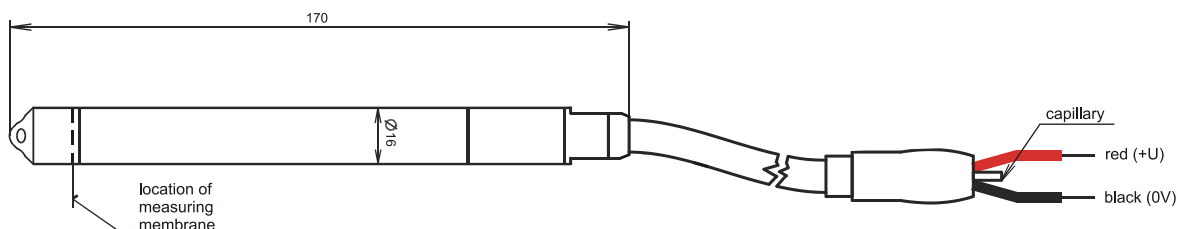

## Installation

When immersed to the reference level the probe may hang freely on the cable or lie on the bottom of the tank. The cable with the capillary can be extended using a standard signal cable. The cable connection should be situated in a non-hermetic box (with internal pressure equal to atmospheric pressure), preventing water or other contaminants from reaching the capillary. When the probe cable is wound up, the winding diameter should be at least 30 cm and the cable should be protected from mechanical damage.

The end of the cable is equipped with a protective diode which clamps if the supply voltage exceeds over permitted value (39V). For this reason the cable supplied by the manufacturer should not be shortened.

In tanks where there is a possibility of turbulence (where mixers operate or where is a turbulent inflow), the probe should be installed in a screening tube (e.g. made from PVC). For easier hanging of the probe a line can be attached to the carrying loop. The probe diaphragm must not be mechanically cleaned.

## Specification system

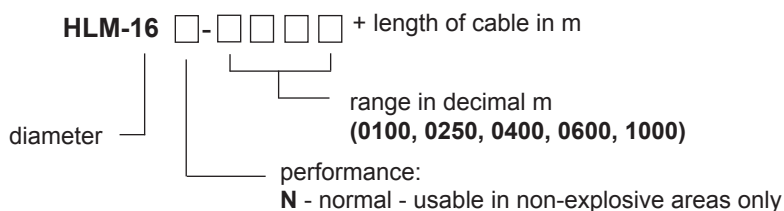
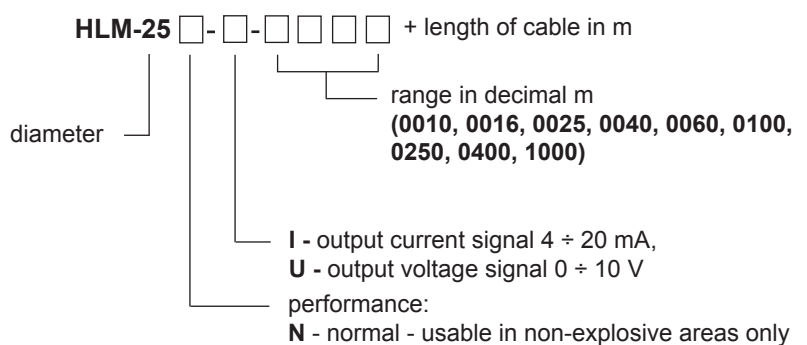

## Electric connection

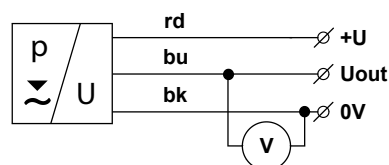
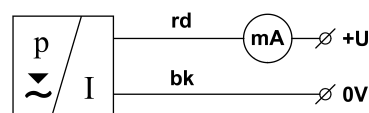

## Example of correct specification

HLM-25N-I-0100 cable 25m  
HLM-25N-U-0016 cable 5m  
HLM-16N-0100 cable 25 m  
HLM-16N-0600 cable 70 m

## Safety, protections and compatibility

Level meter is equipped with protection against reverse polarity, output current overload, short circuit and short time over voltages.

The protection against electric shock is done by safety voltage use.

Electromagnetic compatibility is provided by conformity with standards: EN 55022/B, EN 61000-4-2, EN 61000-4-3, EN 61000-4-4, EN 61000-4-5, EN 61000-4-6.

Dinel, s.r.o., U Tescomy 249, CZ - 760 01 Zlín, Tel.: +420-577 002 003, fax: +420-577 002 007  
E-mail: sale@dinel.cz Web: http://www.dinel.cz



QMS  
ISO 9001