

#### Features

- \* Quick response.
- \* Stainless steel stem provides exceptional durability.
- \* Flange type is available for JIS 10K, ANSI 150LB and PN16.
- \* Ex-proof coil T4 as optional accessory.
- \* Timer for setting on/off time as optional accessory.
- \* CE conformity for all series.
- \* Coil nut is available, please refer to page 7-6.



#### How to order

<b>PU220</b>	<b>A</b>	<b>N</b>	<b>V</b>	<b>F</b>	<b>- 03</b>	<b>N</b>	<b>- S</b>	<b>1</b>	<b>LED</b>	<b>E</b>
Brass 2/2 way assisted lift	Series	Acting style	Diaphragm	Flange type	Port size	Thread	Solenoid	Voltage	LED	Ex-proof coil
	Blank	Normally closed	Blank	NBR	F	10K	03	3/8"	Blank	G
	N	Normally open	V	VITON	F3	150LB	04	1/2"	N	NPT
			E	EPDM	06	3/4"	06	3/4"	R	Rc
			H	HNBR	F4	PN16 only for A series	08	1"		
									Blank	W/O LED
								1	110VAC	
								2	220VAC	
								9	24VDC	

#### Specifications

Model	PU220A-03	PU220A-04	PU220A-06	PU220A-08
Port size	3/8"	1/2"	3/4"	1"
Fluid	Compressed air (light oil, water)			
Orifice	13mm	13mm	20mm	25mm
Sectional area	76mm <sup>2</sup>	76mm <sup>2</sup>	162mm <sup>2</sup>	220mm <sup>2</sup>
Acting	Assisted lift			
Construction	Diaphragm			
Operating pressure range AC	0 ~ 7 kgf/cm <sup>2</sup>			
Operating pressure range DC	0 ~ 6 kgf/cm <sup>2</sup>		0 ~ 5 kgf/cm <sup>2</sup>	
Proof pressure	10 kgf/cm <sup>2</sup>			
Body material / Flange material	Forged Brass / Steel			
Fluid temperature	-10°C ~ 90°C			
Ambient temperature	-10°C ~ 60°C			
Installation	Horizontal			
Duty cycle	100% ED			
Coil type	DIN			
Protection class	IP65 (DIN 40 050)			
Insulation class	F			
Voltage tolerance	±10%			
Standard voltage	220VAC, 110VAC, 24VDC The other voltage is optional			
Power consumption	AC110V:17.6VA, AC220V:18.1VA, DC: 15W			
Net weight	740g	740g	945g	1485g

#### Seal material selection guide

Seal	Temperature range	Suitable fluid	Unsuitable fluid
NBR	-15°C ~ 80°C	Air, Water, Neutral gases, Mineral oil	Fuel oil, Gasoline and Hi-test gasoline, Diesel fuel
HNBR	-40°C ~ 150°C	Air, Water, Gear oil, Engine oil	Pharmaceutical liquid, Gasoline and Hi-test gasoline, Light oil
VITON	-10°C ~ 180°C	Fuel oil, Gasoline and Hi-test gasoline, Diesel fuel	Hot water, Steam, Brake oil (ATE Blue)
EPDM	-5°C ~ 130°C	Hot water, Detergent liquid	Mineral oil, Gasoline

#### Dimensions



#### PU220A-03, 04, 06, 08 Standard type

#### PU220A-03, 04, 06, 08 Flange type (10K)

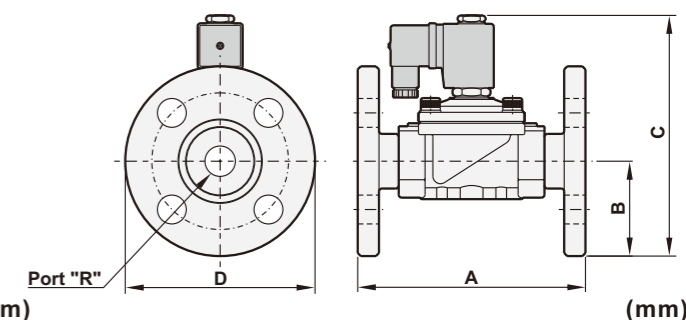
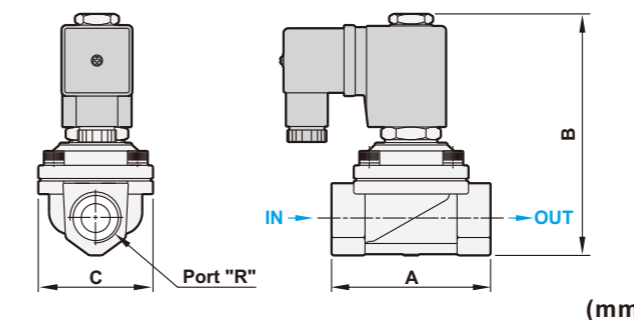

Model	PU220A-03	PU220A-04	PU220A-06	PU220A-08
R	3/8"	1/2"	3/4"	1"
A	66.5	66.5	71.0	96.0
B	101.0	101.0	107.0	120.5
C	48.0	48.0	58.0	70.0

Model	PU220AF-03	PU220AF-04	PU220AF-06	PU220AF-08
R	3/8"	1/2"	3/4"	1"
A	110.0	110.0	120.0	150.0
B	45.0	47.5	50.0	62.5
C	130.5	133.0	138.5	158.5
D	90.0	95.0	100.0	125.0

#### Flow chart

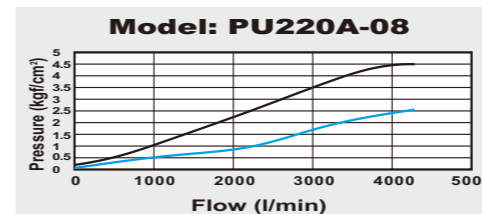
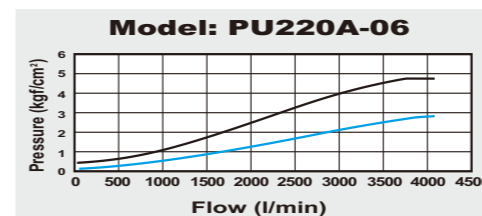
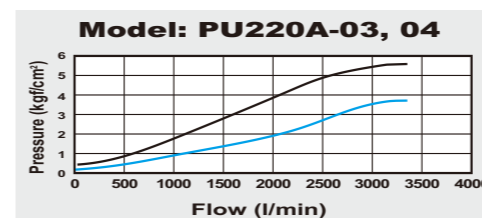

#### Explosion

